

DESIGN NOTES

Number 34 in a series from Linear Technology Corporation

May, 1990

Active Termination for SCSI-2 Bus

Sean Gold

Overview of SCSI-2

The SCSI-2 bus¹ is an interface for computers and instrumentation that communicate over small distances — often within the same cabinet. Like GPIB (IEEE 488), SCSI's hardware and software specifications are designed to coordinate independent resources such as disk and tape drives, file servers, printers, and other computers. SCSI-2 is a bidirectional bus, which must be terminated at both ends to 2.85V (Figure 1). The terminators are needed because SCSI-2 uses simple open collector output drivers in its transceivers. Terminators link communicating devices to the supplies, and roughly match the transmission line's characteristic impedance. When the load to the bus increases, the role of the termination network becomes more important for maintaining signal integrity at high data rates. An active termination design is now a part of the SCSI-2 standard and is presented here in-depth.

The single ended SCSI-2 bus is limited to six meters in length, and supports variable speed communication up to 5M transfers/sec. The bus nominally uses 18 data lines which defines the loading requirements for the terminators, because each output driver can sink at most 48mA. Up to eight SCSI

devices can access the bus at regular distances along the cable. Any two devices can terminate the cable, but bit error rates are minimized with the terminators attached only at the ends. Local capacitive loading is low under these conditions, making the transmission line more consistent with fewer discontinuities.

SCSI-2's key specifications are repeated from the ANSI standard in Table 1.

Table 1. Single Ended SCSI-2

PARAMETER	VALUE	COMMENTS
Termination Supply	$4.25 < \text{TERMPWR} < 5.25$	0.9A Typical 1.5A Worst Case
Logic Supply	$V_{\text{OUT}} = 2.85\text{V}@0.5\text{A}$ $2.6 < V_{\text{OUT}} < 2.9$	Per Terminator
Data Rate	5M Transfers/Sec.	Six Meters Max.
Cable Impedance	110Ω $80 < Z_0 < 140$	Nominal
Transceivers	TTL Compatible	Negative True Logic 5V = 0, 0V = 1
Signal Levels	$0 < V_{\text{OL}} < 0.5$ $2.5 < V_{\text{OH}} < 5.25$ $V_{\text{IL}} < 0.8$ $2.0 < V_{\text{IH}}$ $0.2 < \text{Hysteresis}$	$-0.4\text{mA} < I_{\text{IL}} < 0\text{mA}$ $0.0\text{mA} < I_{\text{IH}} < 0.1\text{mA}$
Short Circuit Current	48mA/Transceiver	Based on Old TTL Spec

Note 1: SCSI-2 = Small Computer System Interface Version 2, pronounced "Scuzy-2." The complete specifications standard is available through ANSI # X3T9.2.

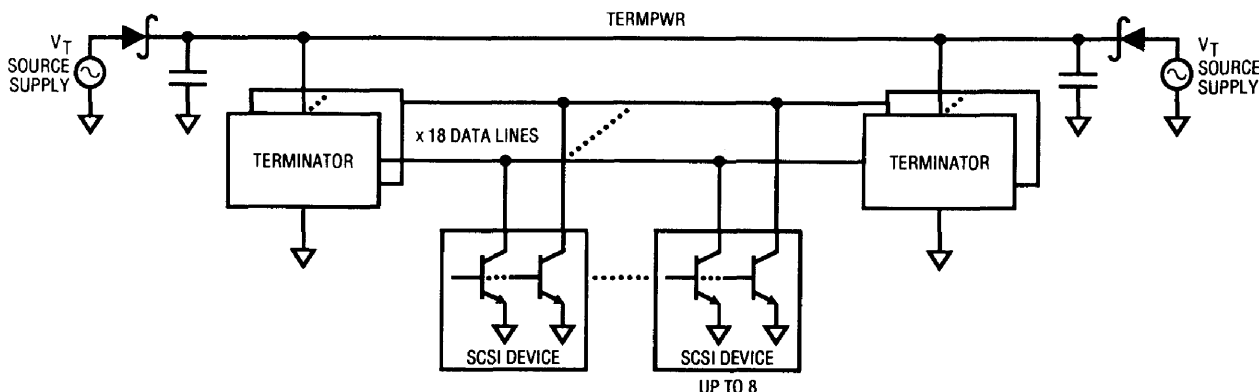

Figure 1. Global View of the SCSI-2 Bus

Shortcomings of Passive Terminators

The resistive voltage divider shown in Figure 2 is commonly used to terminate the SCSI bus. Multiple power sources are allowed to connect to the SCSI cable. Each source is protected with a Schottky diode to prevent damage from reverse currents. The resulting termination power signal, TERMPWR, is not well regulated — subject to variations in source supplies and protection diodes, as well as ohmic losses. Unfortunately, these changes in TERMPWR translate directly to the bus through the resistive divider, which degrades noise margins.

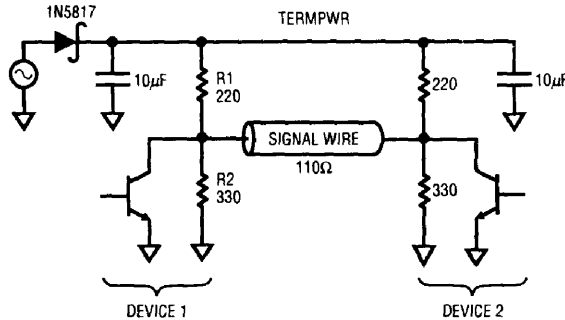

Figure 2. Passive Termination

The low values for R1 and R2 reflect a compromise between driver sink current and impedance matching the signal lines. Normally, high resistances would be desirable to minimize driver sink current. Yet, the terminator should match the signal line's 110Ω characteristic impedance, and the bus's quiescent state must be above the TTL logic threshold. It is not possible to meet all of these objectives simultaneously.

The SCSI standard suggests $R1 = 220\Omega$ and $R3 = 330\Omega$. The resulting bus voltage is 3V with 132Ω impedance, which is mismatched to the nominal 110Ω cable impedance. The Schottky diode aggravates the mismatch because it presents a poor AC ground. In addition to these problems, the small resistors draw 300mA Q-current from TERMPWR, assuming 18 signal lines with the bus inactive.

Active Terminators

The active terminator shown in Figure 3 uses an LT1117-2.85 low dropout regulator to control the logic supply. The LT1117's line regulation makes the output immune to variations in TERMPWR. After accounting for resistor tolerances and variations in the LT1117's reference, the absolute variation in the 2.85V output is only 4 percent over temperature. When the regulator drops out at $TERMPWR - 2.85V = 1.25V$, the output linearly tracks the input with a slope of 1V/V. Signal quality is quite good because the 110Ω series resistor closely matches the transmission line's characteristic impedance, and the regulator provides a good AC ground.

In contrast to the passive circuit, two LT1117s require only 20mA quiescent current. For the power levels in this application, the LT1117 does not need a heat sink, and is available in low cost, space saving, SOT-223 surface mount packages. Beyond solving basic signal conditioning problems, the LT1117 handles fault conditions with short circuit current limiting, thermal shutdown, and on-chip ESD protection circuitry.

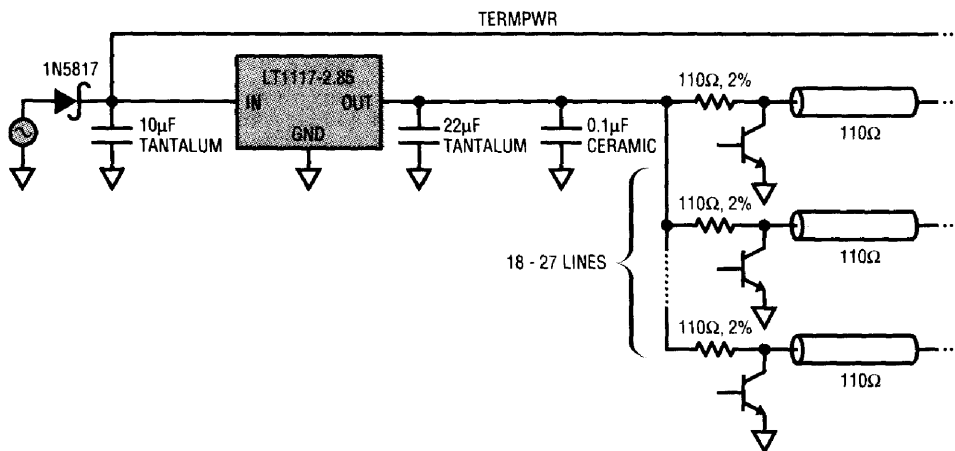

Figure 3. Active Termination

For literature on linear regulators, call (800) 637-5545.
For applications help, call (408) 432-1900, Ext. 209.